



DO NOT RETURN THE PRODUCT TO THE STORE.

IF YOU NEED HELP, CALL THE MASTER CHEF® HOTLINE

1-855-453-2150

GET HELP FOR:

MISSING/DAMAGED PARTS • ASSEMBLY • TROUBLESHOOTING
• WARRANTY ASSISTANCE • PRODUCT INFORMATION

TIP: ASSEMBLE YOUR GRILL IMMEDIATELY. MISSING OR DAMAGED PARTS MUST BE CLAIMED
WITHIN 30 DAYS OF PURCHASE.

GRILL SAFETY CHECK

FOR YOUR FAMILY'S SAFETY, PLEASE CHECK THE FOLLOWING:

- READ** and **UNDERSTAND** the Safety & Care Manual.
- CHECK that the regulator nipple is centred into the LP tank valve. DO NOT cross thread this connection. Cross threading may result in a fire, or explosion at the tank connection.
- PERFORM LEAK TEST** on all connections as specified in this user manual. Leak checks should be performed on all new barbecues even if assembled by an assembler or gas technician. Leak checks should be performed frequently thereafter.
- DO NOT position or operate barbecue under an overhang, or unprotected construction, against a wall, or near aluminum siding, windows or fencing.
- INSPECT** and **CLEAN** burner tubes to avoid flash fires caused by spider webs and other blockages. Inspect gas jets to ensure they are correctly installed in burner tubes. **NEVER LEAVE A LIT GRILL UNATTENDED.**
- BEFORE OPENING THE GAS SUPPLY**, ensure the lid is open, control knobs are in the OFF position, gas is turned off, and the regulator is attached to the tank correctly. Then follow the **PROPER LIGHTING PROCEDURE** as shown in the manual. If above steps are not followed, you may experience low flames, or other performance issues.
- AVOID** dangerous grease fires by performing regular cleaning and maintenance of the interior casting, grease collection system, flame tamers and cooking grates.
- Large yellow flames and the smell of gas indicate a blockage in the burner, usually a spider web. Remove the burner and clear the obstruction.

CAUTION:

IN DIRECT SUN, AND IN OPERATION, YOUR BARBECUE'S STAINLESS STEEL AND PAINTED STEEL PARTS CAN BECOME VERY HOT. PLEASE EXERCISE CAUTION AND DO NOT TOUCH THESE HOT SURFACES.

SAFETY & CARE MANUAL



THIS MANUAL MUST REMAIN WITH THE PRODUCT AT ALL TIMES

To order non-warranty replacement parts or accessories, or to register your warranty,
please visit us on the Web at

www.masterchefbbqs.com

⚠ CAUTION

Read and follow all safety statements, assembly instructions and use-and-care directions before attempting to assemble and cook.

⚠ INSTALLER OR ASSEMBLER/ CONSUMER

This manual should be kept with the barbecue at all times.

⚠ WARNING

Failure to follow all of the manufacturer's instructions could result in hazardous fires, explosions, property damage, or serious personal injury or even death. Follow all leak-check procedures carefully prior to operation of the barbecue, even if grill was dealer assembled. Do not try to light this barbecue without reading the Lighting Instructions section of this manual.

⚠ DANGER

1. If you smell gas:

- a. Shut off gas to the appliance.
- b. Extinguish any open flame.
- c. Open lid.
- d. If odour continues, keep away from the appliance and immediately call your gas supplier or your fire department.

2. Do not store or use gasoline or other flammable liquids or vapours in the vicinity of this or any other appliance.

3. An LP cylinder not connected for use shall not be stored in the vicinity of this or any other appliance.



Quick Start Video
Scan this QR code.



⚠ CAUTION

Some parts may contain sharp edges—wear protective gloves if necessary when handling. For residential use ONLY. Do not use for commercial cooking.

⚠ WARNING

Do not attempt to repair or alter the hose and regulator or valve assembly for any assumed defect or for any type of retrofit or conversion. Any modifications to this assembly will void your warranty and create the risk of a gas leak and fire. Use only authorized replacement parts supplied by the manufacturer for your model.

THIS BARBECUE IS FOR OUTDOOR USE ONLY.

To ensure your satisfaction and for follow-up service, register your barbecue online at www.masterchefbbqs.com

TABLE OF CONTENTS

INSTALLATION AND WARNINGS	4
LP GAS CYLINDER	5
• Requirements	5
• Hook-ups and Warnings	6
• Transportation and Storage	7
SAFETY HOSE AND REGULATOR	8
LEAK TESTING	10
OPERATION—LIGHTING INSTRUCTIONS	11
PREVENTION	13
TROUBLESHOOTING	15
CLEANING AND MAINTENANCE	17
• Seasoning cooking grates	19
START GRILLING	21
WARRANTY AND SERVICE	23

INSTALLATION

Installation must conform with local codes or, in the absence of local codes, with either the National Fuel Gas Code, ANSI Z223.1/NFPA 54, Natural Gas and Propane Installation Code, CSA B149.1, or Propane Storage and Handling for Recreational Vehicles, ANSI A 119.2/NFPA 1192, and CSA Z240 RV Series, Recreational Vehicle Code, as applicable.

ADDITIONAL WARNINGS

Minimum clearance to adjacent combustible materials:
36" (91.4 cm) from furthest protruding edge on all sides of the barbecue.

- **DO** always keep the area around this barbecue clean and clear of any and all combustible materials such as gasoline or other inflammable liquids, paper or oily rags.
- **DO** remember this barbecue is for outdoor use only and is not for use on any boat or recreational vehicle.
- **DO** use this barbecue outdoors in a well-ventilated area placed at least 36" (91.4 cm) from any dwelling or building.
- **DO** always close LP cylinder valve and remove coupling nut before moving LP cylinder from specified operation position.
- **DO** check burner flames regularly.
- **DO NOT** operate this barbecue under or near any overhanging or unprotected construction, aluminum siding, windows, or fencing.
- **DO NOT** use in enclosed spaces such as carport, garage, porch or covered patio.
- **DO NOT** leave your barbecue unattended while in operation.
- **DO NOT** obstruct the flow of combustion and ventilation air to the barbecue. Do not place barbecue against a wall or other solid structure.
- **DO NOT** use while under the influence of drugs or alcohol.
- **DO NOT** store any spare LP (propane) cylinder, full or empty, under or near your barbecue.
- **DO NOT** allow children or pets to play anywhere near the barbecue.
- **DO NOT** block holes in sides or back of grill.
- **DO NOT** use charcoal or ceramic briquettes in a gas grill.
- **DO NOT** attempt to light burner with lid closed. A buildup of non-ignited gas inside a closed grill is hazardous.
- **DO NOT** use grill until leak-tested, and a safety check is completed.
- Minimum ambient operating temperature: 0°F (-18°C).
 - (a) Do not store a spare LP-gas cylinder under or near this appliance.
 - (b) Never fill the cylinder beyond 80 percent full.
 - (c) If the information in "(a)" and "(b)" is not followed exactly, a fire causing death or serious injury may occur.

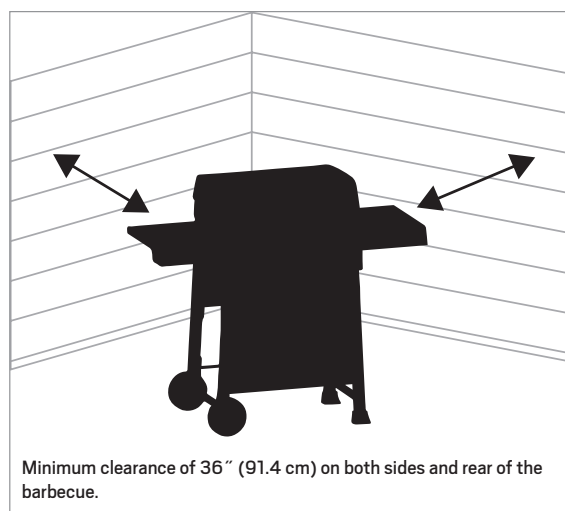

LP GAS CYLINDER REQUIREMENTS

DO NOT connect to a propane cylinder exceeding 20 lb (9.1 kg) capacity or use a cylinder with any other type of cylinder valve connection device.

LP gas supply cylinder must be constructed and marked in accordance with the specifications for LP gas cylinders of the US Department of Transportation (DOT) or the National Standard of Canada, CAN/CSA-B339, Cylinders Spheres and Tubes for the Transportation of Dangerous Goods.

GAS HOOK-UPS AND AND WARNINGS

(LP) LIQUID PETROLEUM GAS:

- LP gas is non-toxic, odourless and colourless when produced. For your safety, LP gas has been given an odour (similar to rotten cabbage) so that it can be smelled.
- LP gas is highly flammable and may ignite unexpectedly when mixed with air.

LP CYLINDER REQUIREMENTS:

- 12" (30.5cm) diameter x 18" (45.7 cm) tall with 20 lb (9 kg) capacity maximum.
- LP cylinders must be constructed and marked in accordance with specifications for LP cylinders of the US Department of Transportation (DOT) or the National Standard of Canada, CAN /CSA-B339, cylinders spheres and tubes for transportation of dangerous goods. See LP cylinder collar for marking.

LP CYLINDER VALVE MUST HAVE:

- **Shut-off valve** with a correct cylinder valve output as specified in current standards. CSA/ANSI Z21.58-2022/CSA1.6-2022 Outdoor Cooking Gas Appliances.
- Type 1 outlet compatible with regulator or grill. The type 1 valve is easily recognized by the large external thread on the outside of the valve.
- Safety relief valve with direct connection to the vapour space of the cylinder.
- **UL listed Overfill Protection Device (OPD)**. This OPD safety feature is identified by a unique triangular hand wheel. Use only LP cylinders equipped with this type of valve.
- A device for vapour withdrawal.
- A collar to protect the LP tank shut off valve.
- A ring on the bottom of the LP tank to secure it to the support assembly.
- Place dust cap on cylinder valve outlet whenever the cylinder is not in use. Only install the type of dust cap on the cylinder valve outlet that is provided with the cylinder valve. Other types of caps or plugs may result in leakage of propane.

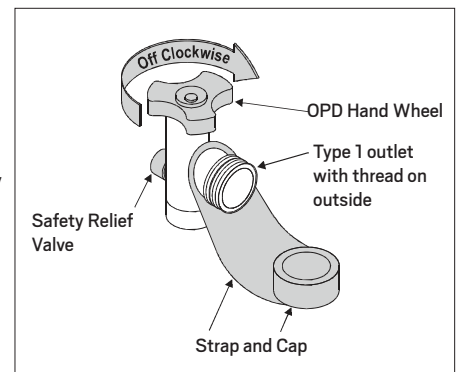

⚠️ LP CYLINDER WARNINGS

- Inspect the LP cylinder valve rubber seal for cracks, wear, or deterioration prior to use. A damaged rubber seal can cause a gas leak, possibly resulting in an explosion, fire, or severe bodily harm.
- Inspection should be done each time the LP cylinder is connected to the grill, has been refilled, exchanged, or has not been used for more than 60 days.
- Do not use an LP cylinder with a damaged rubber seal. Exchange the LP cylinder or have the rubber seal replaced at a qualified propane filling station

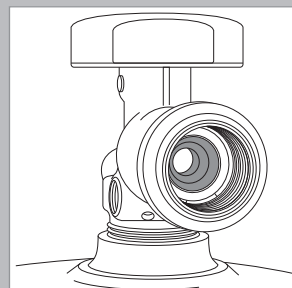

Good Rubber Seal

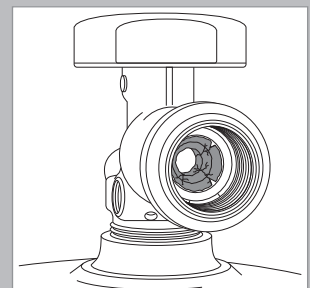

Damaged Rubber Seal

GAS HOOK-UPS AND WARNINGS

⚠️ LP CYLINDER WARNINGS

- Always turn cylinder valve off when the barbecue is not in use.
- Always handle the tank valve with the utmost care.
- Never connect an unregulated LP gas cylinder to the barbecue.
- Always keep the cylinder, in use, securely fastened in an upright position.
- Never expose the cylinder to direct sunlight or excessive heat.
- Never insert any kind of object into the valve outlet as this may cause damage to the back-check. A damaged back-check can leak resulting in fires, explosions, property damage, severe injuries or death.
- Do not store an LP cylinder in enclosed spaces such as a carport, garage, porch, covered patio or other building. Make sure the storage area has a lot of ventilation.
- Do not store an LP cylinder in an area where children play.

⚠️ WARNING

Any attempt to connect a regulator to any connectors other than the mating TYPE -1 connector could result in fires, explosions, injuries, or property damage. Use only LP cylinders equipped with this type of valve.

DO NOT connect to a propane cylinder exceeding 20 lb (9.1 kg) capacity or use a cylinder with any other type of cylinder valve connection device.

Before opening LP cylinder valve, check the coupling nut for tightness.

⚠️ DANGER

- **NEVER** store a spare LP cylinder, empty or full, under or near the appliance.
- Never fill a cylinder beyond 80% full.
- An overfilled or improperly stored cylinder is a hazard due to possible gas release from the safety relief valve. This could cause an intense fire or explosion with risk of property damage, serious injury or death.
- Do not store objects or materials inside the barbecue cart enclosure that would block the flow of combustion air to the underside of either the control panel or the burner box.
- If you see, smell or hear gas escaping, immediately get away from the LP cylinder/appliance and call your fire department.



OUTDOOR

- An appliance is considered to be outdoors if installed with shelter no more inclusive than with walls on three sides, but with no overhead cover; all openings must be permanently open; sliding doors, garage doors, windows, or screened openings are not considered as permanent openings;
- An appliance is considered to be outdoors if installed with shelter no more inclusive than within a partial enclosure that includes an overhead cover and no more than two sidewalls. The sidewalls may be parallel, as in a breezeway, or at right angles to each other; all openings must be permanently open; sliding doors, garage doors, windows, or screened openings are not considered as permanent openings; or
- An appliance is considered to be outdoors if installed with shelter no more inclusive than within a partial enclosure that includes an overhead cover and three sidewalls, as long as 30% or more of the horizontal periphery of the enclosure is permanently open. All openings must be permanently open; sliding doors, garage doors, windows, or screened openings are not considered as permanent openings.

LP CYLINDER REMOVAL, TRANSPORT AND STORAGE

BEFORE DISCONNECTING THE LP CYLINDER:

1. Turn “OFF” all control knobs and the LP cylinder valve.
2. Turn coupling nut counter-clockwise by hand only—do not use tools to disconnect. Remove LP cylinder from inside cart.
3. Install safety cap onto LP cylinder valve. Always use cap supplied with tank valve.

Failure to use safety cap as directed may result in serious personal injury and/or property damage.

WARNING

When transporting and storing the cylinder, make sure it is in an upright position and not on its side. Do not smoke around cylinder, especially when transporting in a vehicle.

LP CYLINDER FILLING

- Use only licensed and experienced dealers.
- Ensure that the dealer checks and tests the tank for leaks after filling.
- LP dealer must purge new cylinder before filling.
- Dealer should NEVER fill LP cylinder more than 80% of LP cylinder volume. Volume of propane in cylinder will vary by temperature.
- Do not release liquid propane LP gas into the atmosphere. This is a hazardous practice.
- To remove gas from LP cylinder, contact an LP dealer or call a local fire department for assistance.

WARNING

If the above instructions are not completely adhered to, a fire/explosion could occur, resulting in death or serious injury, or property damage.

CAUTION

A frosty regulator indicates gas overfill. Immediately close LP cylinder valve and call local LP gas dealer for assistance.

SAFETY HOSE AND REGULATOR

PROPANE MODELS:

Your barbecue is designed to operate on LP gas at a pressure of 2.74 Kpa (11" water column). A regulator preset to this pressure is supplied with your barbecue.

QCC-1 QUICK CLOSING COUPLING

All models are designed to be used with an LP gas cylinder equipped with the new QCC-1 Quick Closing Coupling system.

The QCC-1 system incorporates new safety features required by the Canadian Standards Steering Committee.

- Gas will not flow until a positive connection has been made.
- A thermal element will shut off the flow of gas between 240° and 300°F (116° and 149°C).
- When activated, a Flow Limiting Device will limit the flow of gas to 10 cubic feet per hour.

CONNECTING REGULATOR TO THE LP CYLINDER

1. LP cylinder must be properly secured onto grill.
2. Turn all control knobs to the "OFF" position.
3. Turn LP cylinder "OFF" by turning hand-wheel clockwise to a full stop.
4. Remove the protective cap from LP cylinder valve. Always use cap and strap supplied with valve.
5. Hold regulator and insert nipple into LP cylinder valve. Hand-tighten the coupling nut. Hold the regulator in a straight line with LP cylinder valve so as not to cross-thread the connection.
6. Turn the coupling nut clockwise and tighten to a full stop. The regulator will seal on the back-check feature in the LP cylinder valve, resulting in some resistance.

Note:

If you cannot complete the connection, disconnect regulator and repeat steps 5 and 6. If you are still unable to complete the connection, do not use this regulator!

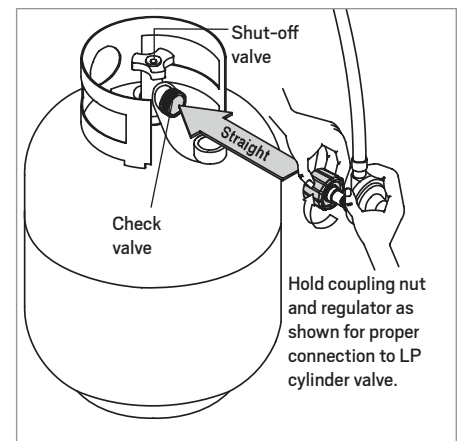
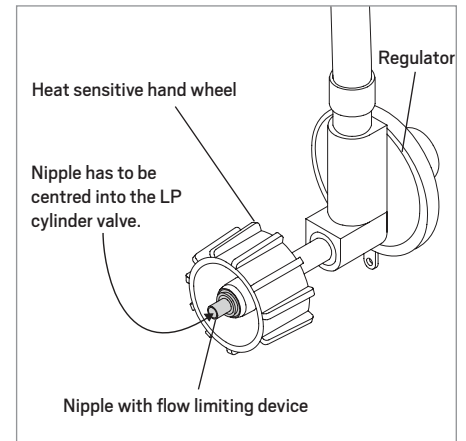

⚠ DANGER

Do not insert any tool or foreign object into the valve outlet or safety relief valve. You may damage the valve and cause a leak. Leaking propane may result in explosion, fire, severe personal injury, or death.

SAFETY HOSE AND REGULATOR

REGULATOR FLOW LIMITING DEVICE

If you are experiencing any of the following performance issues you may have activated the flow-limiting feature in your regulator:

- Burners not getting hot enough
- Low or incomplete burner flames
- Low gas pressure
- Burners not staying lit

RESETTING THE REGULATOR FLOW-LIMITING FEATURE

1. With all control knobs and the gas source in the “OFF” position, open the barbecue lid.
2. Disconnect the hose and regulator from the propane tank.
3. Turn all barbecue control knobs to the “MAX” position.
4. Let stand for 1–3 minutes, allowing all excess gas in valves and manifold to dissipate.
5. Turn all barbecue control knobs back to the “OFF” position.
6. With the barbecue lid still open, reconnect the hose and regulator to the propane tank; do not cross-thread the connection. Hand-tighten only.
7. Check all hose connections to ensure that a positive seal has been made. Perform a leak test.
8. Slowly turn on the propane gas supply, $\frac{1}{4}$ to $\frac{1}{2}$ turn.
9. Wait approximately 5 seconds for the hose and regulator pressure to stabilize.
10. Turn the selected burner control knob to the “MAX” position
11. Press the electronic ignition button, or use a match and match holder, or a butane lighter to ignite the selected burner.

Avoid activating the Flow-Limiting Feature by following the proper start-up and shut-down procedures and performing a complete leak test and safety check to ensure that there are no leaks in the system, and that a positive connection has been made between the gas source and manifold assembly.



Flow Limiting Feature Video
Scan this QR code.



LEAK-TESTING THE VALVE, HOSE AND REGULATOR ASSEMBLY

1. Turn all grill control knobs to "OFF".
2. Ensure that the regulator is tightly connected to LP cylinder.
3. Completely open LP cylinder valve by turning hand wheel counter-clockwise. If you hear a rushing sound, turn gas off immediately; there is a leak at the connection. Correct before proceeding.
4. Brush soapy solution onto hose and regulator and all connections from the LP tank to the main and side burner manifold.
5. If "growing" bubbles appear, there is a leak. Close LP cylinder valve immediately and re-tighten connections. If leaks cannot be stopped do not try to repair. Call for replacement parts. Order new parts by providing the serial number, model number, name and part number of items required (see parts list) to a Customer Care Agent 1-855-453-2150.
6. Always close LP cylinder valve after performing leak test by turning hand wheel clockwise.



LP CYLINDER LEAK-TEST FOR YOUR SAFETY



Leak Test Video
Scan this QR code.



⚠ ATTENTION:

A leak test must be repeated each time the LP cylinder is exchanged or refilled.

- Do not smoke during a leak test.
- Do not use an open flame to check for gas leaks.
- Barbecue must be leak-tested outdoors in a well-ventilated area, away from ignition sources such as gas-fired electrical appliances. During a leak test, keep your barbecue away from open flames or sparks.
 - Use a clean paint brush and a 50/50 mild soap and water mixture.
 - Brush soapy solution onto areas indicated by arrows in Figure A.

DO NOT USE HOUSEHOLD CLEANING AGENTS:
Damage to gas train components can result.

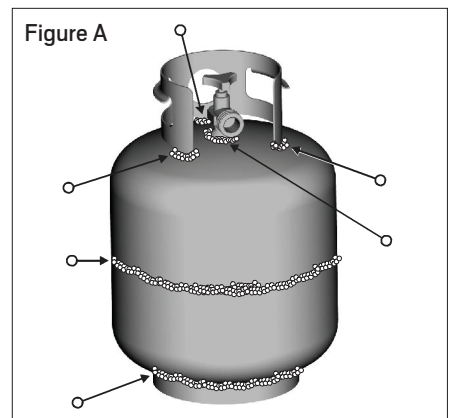

⚠ WARNING

If growing bubbles appear, do not use or move the LP cylinder. Contact an LP gas supplier or your fire department.

⚠ ATTENTION

If it is evident there is excessive abrasion or wear, or the hose is cut, it must be replaced prior to the outdoor cooking gas appliance being put into operation. The replacement hose assembly shall be that specified by the manufacturer.

OPERATION — LIGHTING INSTRUCTIONS

LIGHTING THE MAIN BURNER:

1. Open the lid.
2. Make sure all burner control knobs are turned “OFF”.
3. SLOWLY, open the LP cylinder valve (turn counter-clockwise). Wait for pressure to stabilize for 5 seconds.
4. Push in and turn the lighting burner control knob, counter-clockwise to the “MAX” position (⚡).
5. Press the ignition button.
6. Check that the burner is lit. Repeat step 5 if necessary.
7. After the lighting burner is lit, push in and turn all the other control knobs to the “MAX” position.
8. Check that all burners are lit. If the burner fails to light properly within 3–5 seconds, turn the burner control knob and the LP cylinder valve “OFF”. Wait five minutes before attempting to light the burner again. This will allow time for released gas to dissipate.



Lighting
Instruction Video
Scan this QR code.



⚠ WARNING

Never stand with your head directly over the barbecue when preparing to light the main burners, to prevent possible bodily injury.

⚠ ATTENTION

Once lit, confirm that the burner is properly lit and that the flame pattern is as desired. If the flame pattern is other than normal, consult the troubleshooting guide for corrective action.

MATCH-LIGHTING MAIN BURNERS

IMPORTANT: When match-lighting the barbecue use the control knob closest to the match-lighting hole.

Repeat steps 1 to 3 of “**LIGHTING THE MAIN BURNERS**” above.

1. To match-light: push in and turn the control knob counter-clockwise to the “MAX” position (⚡).
2. Immediately strike a match or use a butane lighter and position through the lighting hole on the left side of the burner box. The burner will light.
3. To light the other burners, press in and turn the nearest control knob. The flame will light via the carryover tubes. Allow the grill to preheat with the grill lid closed for 10–15 minutes before cooking.

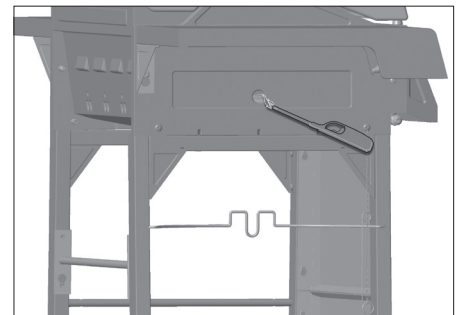

Model may not be exactly as shown.

OPERATION — LIGHTING INSTRUCTIONS

⚠ CAUTION

The side burner lid must remain opened before, during and until the side burner has cooled.

LIGHTING THE SIDE BURNER (If applicable)

1. Turn the burner control knob to the “MAX” position (⚡). Wait 5 seconds.
2. Press the igniter button. You will hear a click sound. Repeat if necessary.

⚠ CAUTION

If side burner fails to light, immediately turn burner control knob “OFF” and wait 5 minutes before re-lighting with a match.

MATCH-LIGHTING THE SIDE BURNER (If applicable)

1. Open lid. Turn “OFF” all control knobs. Ensure LP cylinder valve is closed.
2. Open the LP cylinder valve (1 to 2 turns).
3. Turn the side burner control knob to the “MAX” position (⚡). Wait 5 seconds.
4. Insert a lit match or a butane lighter under the side burner grate. Ignition should take place immediately. .

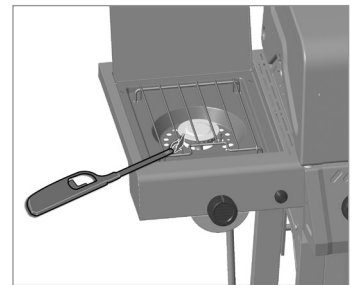

Model may not be exactly as shown.

⚠ CAUTION

If ignition does NOT occur in 5 seconds, turn the burner controls “OFF”, wait 5 minutes and repeat the lighting procedure. If the burner does not ignite with the valve open, gas will continue to flow out of the burner and could accidentally ignite with risk of injury. Turn controls and gas source “OFF” when not in use.

⚠ ATTENTION

Always preheat barbecue before starting to cook. Light all burners and adjust them to the “MAX” position with the lid closed, until the desired temperature is reached. Following preheat, adjust the controls to low/medium setting for most cooking requirements.

SHUT-DOWN PROCEDURE

1. Turn all control knobs to the “OFF” position.
2. Turn LP cylinder off by turning hand-wheel clockwise to a full stop.

⚠ WARNING

If the heat output is too low, the “Flow Limiting” feature may have been activated by a gas leak or improper lighting procedure. If so, turn “OFF” all control knobs and cylinder valve, and perform a “Leak Test”. If there are no leaks, perform a complete regulator “Flow Limiting Device” reset.

PREVENTION

⚠ ATTENTION

Once lit, confirm that the burner is properly lit and that the flame pattern is as desired. If the flame pattern is other than normal, consult the troubleshooting guide for corrective action.

BURNER FLAME CHECK

Always do a visual check of all burners prior to lighting. Burners have been factory set for the correct air and gas mixture. The correct flame pattern is shown in Figure A. If you experience one of the following symptoms, follow the burner cleaning procedure outlined in the maintenance section of this manual, or reset the regulator flow-limiting device.

- Large, unruly, or irregular orange burner flames.
- The smell of gas in conjunction with orange and lazy burner flames.
- Barbecue does not reach temperature.
- Barbecue heats unevenly.
- One or more of the burners do not ignite.

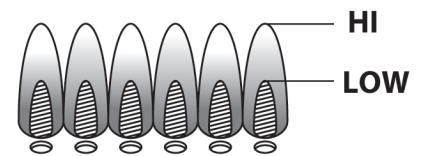

Figure A

FLASH-BACK FIRES

Spiders and insects are attracted to the smell of propane and often build nests inside your barbecue's burners, which is the root cause of a FLASH-BACK FIRE. Lighting your burners without first checking and cleaning out the venturi tubes, burner ports, and the inside of burners can lead to a serious flash-back fire resulting in damage to the barbecue, property and/or personal injury.

Characteristics of a Flash-Back Fire

- Hot or melting control knobs.
- Burners may burn with large yellow flames.
- Burners may not light.
- A fire burning outside of the burner box, usually visible behind or under the control panel.

Prevent Flash-Back Fires by:

- Remove burners to clean and check for blockages – perform burner safety and maintenance checks.

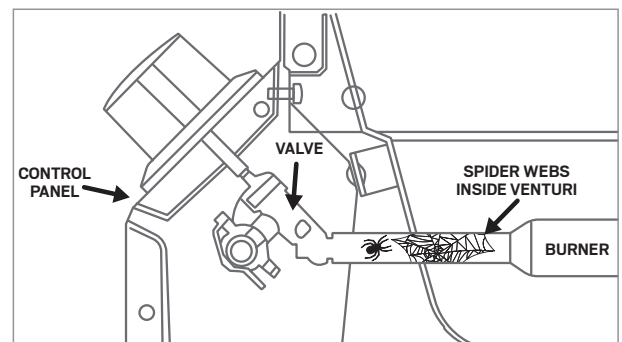

PREVENTION

GREASE FIRES

Characteristics of a Grease Fire

- A fire burning inside the barbecue burner box may become uncontrollable if not monitored.
- Usually accompanied by high flames, a lot of smoke and black soot.
- May cause charring on the interior of barbecue lid, lid side panels (inside and outside), may damage temperature gauge, cause brownish colouring on stainless steel lids and soot and ash buildup on cooking grates.

Prevent Grease Fires by:

- Removing grease buildup on key parts such as flame tamers, cooking grates, and burner box.
- Frequently cleaning the grease collection plate and grease cup.
- Always reduce cooking temperature to “MED” or “MIN” heat, following PREHEAT.
- Burning off buildup on the cooking grates and heat plates after each use.

FOR YOUR SAFETY

- **DO NOT** throw water on a grease fire.
- **DO** make sure that you follow all safety checks, maintenance procedures and instructions outlined in this manual before operating the barbecue.
- **DO** protect your family and home by performing regular cleaning and maintenance of key barbecue parts including burners, flame tamers, grease tray and cooking grates.
- **DO** keep baking soda handy to extinguish a fire.



TROUBLESHOOTING

PROBLEM	IDENTIFYING THE CAUSE:
Burners will not light (with igniter or match).	<ul style="list-style-type: none"> • Positive connection has not been made between the tank and the regulator. • Flow-limiting device in regulator has been activated. See resetting the regulator flow limiting device on page 9. • Burners are not properly seated over valve orifices. • Low or out of propane. • Gas supply valve is turned off.
Burners will not light with the igniter (no spark).	<ul style="list-style-type: none"> • Loose electrode wires. • Broken electrode–ceramic casing around electrode damaged. • Faulty electronic ignition box.
Fire at control knob and control panel = flash-back fire.	<ul style="list-style-type: none"> • Blockage inside of burner – flash-back fire. • Burner is improperly seated over gas jet.
Yellow smokey flames/ gas odour can be smelled.	<ul style="list-style-type: none"> • Blockage inside of burner – check for spider/spider web.
Flame blows out on “MIN”.	<ul style="list-style-type: none"> • High wind condition – Adjust barbecue to shield from wind. • Flow-limiting device in regulator has been activated. See resetting the regulator flow-limiting device on page 9. • Low or out of propane. • Burner improperly seated on gas jet.
Low heat generated with knob in “MAX” position.	<ul style="list-style-type: none"> • Make certain the problem is isolated to only one burner. If it appears so, the burner and/or burner tubes are blocked. • Flow-limiting device in regulator has been activated. See resetting the regulator flow-limiting device on page 9. • Check for a bent or kinked fuel hose. • Pre-heat with the lid closed for 15 minutes. (In colder temperatures preheat for longer periods.)

TROUBLESHOOTING

PROBLEM	IDENTIFYING THE CAUSE:
Low or incomplete flame (assuming burners and venturi tubes are free and clear of blockages).	<ul style="list-style-type: none"> • Flow-limiting device in regulator has been activated. See resetting the regulator flow-limiting device on page 9.
Too much heat/Excessive flare up.	<ul style="list-style-type: none"> • Cooking on the "MAX" setting, without adjusting temperature control. • Grease buildup around burner system causing overheating. • Grease collection plate and grease cup need to be cleaned. • Lid open when grilling.
Inside of lid is peeling, like paint peeling.	<ul style="list-style-type: none"> • The interior lid is aluminum, not painted. Baked-on grease buildup has turned to carbon and is flaking off. Clean thoroughly.
Decreasing heat, "popping sound".	<ul style="list-style-type: none"> • Out of propane. • Burner and/or burner tubes are blocked.
Humming noise from regulator.	<ul style="list-style-type: none"> • Cylinder valve opened too quickly.
Melting gas supply hose.	<ul style="list-style-type: none"> • Leak at LP cylinder and hose connection. • Poor ventilation caused by inappropriate clearance at the sides and rear of the barbecue. • Overheating caused by high cooking temperatures and grease buildup. • Your barbecue's gas supply hose and regulator contains a thermal element that will shut off the flow of gas between 240° and 300°F (116° and 149°C) by melting the supply hose and essentially disconnecting from the LP cylinder.

CLEANING AND MAINTENANCE

Cleaning and maintaining your barbecue ensures your family's safety, optimal parts performance, and a long life for your barbecue. Perform at the start of the season, and at least twice in-season, more if the barbecue is being used frequently or year-round.

If you are experiencing any of the following performance or safety issues including but not limited to: 1) barbecue not reaching temperature potential, 2) yellow burner flames, 3) you smell gas, 4) popping noises, 5) delayed burner ignition, 6) uneven heat, 7) flash fires, or 8) grease fires, TURN "OFF" YOUR GRILL immediately and perform the 30 minute maintenance regime shown below.

30 MINUTE BARBECUE MAINTENANCE

Barbecue maintenance should be performed at the beginning of the season before removing the barbecue from storage, and at least twice during the barbecue season (more if the barbecue is being used frequently and/or year-round).

1. Clean barbecue grill housing and lid.
2. Remove and clean the burners, flame tamers, cooking grates, warming rack and grease tray.
3. Reassemble all parts removed and ensure proper placement.
4. Perform leak test and safety check on all connections.

BARBECUE HOUSING AND LID

- Always ensure that the barbecue is cool prior to cleaning.
- Remove the warming rack, cooking grates, flame tamers, and burners.
- Use a plastic scraper to remove buildup, food residue and ashes inside the barbecue housing and lid.
- If necessary, wash the inside of the barbecue burner box with a detergent-and-water solution. Always rinse and dry thoroughly before reinstalling parts. To restore luster to parts wipe with a cloth dipped in cooking oil.

FLAME TAMERS (Heat Distribution Plates)

- Always perform regular maintenance on your flame tamers to remove all debris. Do not allow fats or salty and acidic drippings from marinades to accumulate on your flame tamers.
- Remove and clean heat plates every other time you barbecue or more frequently if cooking for a large group of people.
- Using a grill brush, brush away any buildup from flame tamers. Clean away all remaining debris with mild soap and warm water. Dry thoroughly.
- If your barbecue is being stored outdoors you should clean, remove, and store your flame tamers along with your cooking grates, burners, and igniter battery indoors.
- Prevent moisture and corrosive agents from settling on the surface.

Failure to do all of the above will lead to rapid deterioration of this part. Without removing all heat plates and inspecting them you may not realize the degree of deterioration caused. Following all instructions within this document will ensure a long life for this part and the best performance of your barbecue.

CLEANING AND MAINTENANCE

CLEANING THE GREASE CUP

- The grease cup is located below the burner box of the appliance and is accessible from the rear of the barbecue. It will catch any grease dripping and food residue that is not burnt off during cooking.
- Always wait for grease to cool before removing the grease cup.
- The grease cup should be emptied regularly to prevent possible flare-ups, spillage or grease fires.

CLEANING BURNERS AND VENTURI TUBES

1. Remove the cooking grates and flame tamers to reveal the burners.
2. To remove burner you must first remove the hardware used to assemble the burner into the burner box.
3. Remove the burners.
4. Brush the outer parts of the burner using a wire or brass bristled brush.
5. Using a flexible wire open paper clip, or a drill bit, probe each port hole to clear it of grime and rust.
6. Using a venturi brush, or bottle cleaning brush, clean the interior of the burner. Special care should be taken to make sure the brush passes through the entire burner interior.

CAUTION

Do not use anything larger in diameter than the port hole itself as this may cause damage to the burner port holes.

7. Lightly tap the burner to remove any residue that has been dislodged from the ports and tube. Compressed air can be used to flush out any debris.
8. Visually check the gas jets at the end of each of the valves, for dirt, dust and spider webs. Clean them if necessary.
9. Re-install burners using hardware removed. Ensure that the burners are installed correctly with venturi tubes seated correctly over valve gas jet, and firmly in place.
10. Re-install flame tamers and cooking grates.

CLEANING PORCELAIN CAST IRON COOKING GRATES (If applicable)

Tips:

- Always protect cooking grates against RUST/CORROSION, water, humidity, and moisture damage by following the seasoning steps outlined below.
- Prior to preheating the barbecue, remove all buildup from cooking grates using a grill brush.
- Prep cooking grates with a light coating of vegetable shortening or cooking oil.

CLEANING AND MAINTENANCE

HOW TO SEASON PORCELAIN CAST IRON COOKING GRATES (If applicable)

1. Remove cooking grates from barbecue and brush away all loose or chipping porcelain and grease buildup, using a barbecue brush.
2. Wash cooking grates with soap and water.
3. Rinse and dry thoroughly with paper towels.
Important: Never soak or let soapy water sit on the grates for any length of time.
4. Coat entire cooking grate, top, bottom, sides and each rod with vegetable shortening. DO NOT use salted fat such as margarine, butter, or any non-stick cooking spray. Do not use olive oil as it burns off at high temperatures.
5. Place cooking grates in either your conventional oven, on a cookie sheet, or in your barbecue for up to 20 minutes at 250° to 300°F (121° to 149°C) to complete the seasoning process. Time may vary depending on cooking appliance.
6. Once completed, the cooking grates must be allowed to cool down before use.

CARING FOR PORCELAIN COATED COOKING GRATES (If applicable)

ATTENTION

When cleaning porcelain cooking grates special care must be taken. Although porcelain is a very hard material, it can be easily damaged if handled incorrectly.

The following tips will help you get a long life from the porcelain coating:

1. Handle your porcelain coated grates with care. The material is very brittle. Banging them around, hitting them with metal utensils or other hard objects, and bending are a few things that should be avoided.
IMPORTANT: Following any cleaning and maintenance, cooking grates MUST be coated with a quality cooking oil including vegetable oil or vegetable shortening. Do not use olive oil as it burns off at high temperatures.
2. Carefully remove the cooking grates.
3. Using a wash cloth with warm water and dish soap, scrub the grease and food particles off as best you can. If cleaned regularly, most of the residue will come off easily. Note: High temperature grilling will cause the food to adhere more tightly. If this is the case, soak a large towel in warm water and lay it over the grate. Let it sit for a half hour or so, and then scrub it with the wash cloth.
4. Use a plastic scrubber and soapy water when deeper cleaning is required. Don't use a scrubber that is abrasive. Harsh, abrasive cleansers will scuff up the porcelain and destroy the non-stick properties.
5. Rinse the grate with clean water and dry it with a clean towel. Place it back into your grill.
6. Before heating up the grill for the next cookout, coat the surface with vegetable shortening for added protection and non-stick benefits.

CLEANING AND MAINTENANCE

CLEANING STAINLESS STEEL PARTS

To protect the appearance and integrity of stainless steel surfaces, routine cleaning is essential. Contaminants vary greatly in their effect on appearance, corrosivity and ease of removal. Identify the contaminant or experiment with various cleaners in order to resolve issues including the removal of free-iron contamination. It is impossible to wear out the stainless steel by excessive cleaning, but is possible to damage the stainless steel components and damage the corrosion resistance using products NOT made for a stainless steel outdoor appliance.

Cleaning Stainless Steel Surfaces:

- Ensure that all stainless steel surfaces are wiped down frequently with a basic vinegar and water solution. If there are other cleaners being used ensure that they are specifically for stainless steel OUTDOOR USE. Regardless of instructions all cleaners must be rinsed off and dried with a soft cloth.
- Most cleaners may have corrosive agents and MUST be rinsed off and the surface dried thoroughly.
- Always find a small and inconspicuous spot to test cleaners before cleaning the entire barbecue.
- Ordinary carbon steel brushes or steel wool MUST NOT be used to clean stainless steel. They will scratch the finish and leave particles embedded on the surface that will corrode.
- Your MASTER Chef® barbecue uses both stainless steel 430 and silver powder coated paint. To clean and maintain your barbecue's surfaces DO NOT use any chemical cleaners, as they may strip and cause permanent damage to the painted surfaces. MASTER Chef® barbecues only recommend using a 50/50 mixture of vinegar and water for removing surface dirt and contamination, and a dry soft cloth for polishing. Micro fibre cloths are highly recommended.

STORING YOUR BARBECUE

To avoid barbecue deterioration and degradation of parts, please perform the following tasks prior to storing your barbecue for the season.

- Remove and clean all barbecue components as outlined in the care and maintenance section of this manual.
- If storing unit away for the winter or for a prolonged period of time, remove your cooking grates, flame tamers, burners and the ignition battery and store indoors. Removing and storing parts indoors will help avoid moisture damage and corrosion.
- Be sure to wrap your cooking grates, heat plates, and burners in towels when not in use, storing in a dry area, or season and wrap in newspaper, storing indoors.
- **If storing the barbecue indoors:** the propane cylinder MUST be removed. The propane cylinder MUST always be stored outdoors, in a well ventilated area. When storing your barbecue in a garage, you should place a piece of cardboard underneath your barbecue to protect it from premature corrosion.
- **If storing the barbecue outdoors:** the propane cylinder valve must be turned off. Cover the barbecue. DO NOT under any circumstances store the propane cylinder in the garage or near any heat source. Use a barbecue cover to help protect your barbecue from the direct environment (i.e., rain, snow, animal droppings, etc.). However, please keep in mind that this will not protect your barbecue from moisture, condensation, and other corrosive agents. Routine cleaning is necessary.

ATTENTION

To avoid barbecue deterioration and degradation of parts, follow all maintenance and storage instructions. Take immediate action to clean and perform maintenance on any parts showing signs of weathering or corrosion.

START GRILLING

GRILLING TIPS

- Create an improved, non-stick cooking surface by coating all cooking grates with vegetable shortening or cooking oil before preheating.
- To reduce flare-ups keep the barbecue clean, cook lean cuts of meat, trim excess fat and avoid cooking over “MAX” temperatures.
- Always preheat the appliance on “MAX” to desired temperature, before adding food.
- Always ensure that the temperature is adjusted following preheat. “MAX” is intended for fast pre-heating of the appliance, searing steaks and other cuts of meat.
- Medium and low heat is intended for most grilling, baking and roasting.
- Never pierce meat with a fork.
- Turn foods only once, halfway through cooking time.
- Do not add salt to meat until 15 minutes before grilling as it may reduce the “juiciness” of the meat.
- Do not place frozen meats on the barbecue cooking grates as this will permanently damage the cooking surface. Thaw at room temperature or in a fridge.
- When basting food wait until approximately halfway through the cooking cycle before adding sauces.
- Always cook with the lid down to preserve the barbecue’s temperature.
- **After every use, allow barbecue to cool, empty grease pan, wipe outside surfaces with a suitable cleaner, dry and protect surfaces with a grill cover.**

ATTENTION

Cooking grates must be seasoned before first use. Refer to the instructions on page 19. For best results use vegetable shortening.

GENERAL SIDE BURNER TIPS (If applicable)

Your side burner will boil, sauté, stir fry and warm with ease.

- For best results preheat your side burner for 10–15 minutes on “MAX”.
- When boiling water or warming foods always ensure that you are using a covered pot or wok.
- Ensure that your gas barbecue is positioned away from high winds or cold air as this will adversely affect your side burner preheating and cooking performance.
- Your 10,000–13,000 BTUs side burner will take longer to preheat and cook than your indoor range.
- Remove all food residue and dirt on burner surface.
- Inspect and clean your side burner orifice periodically and confirm that it is clear of food residue, cobwebs or other insect debris that may cause a FLASH FIRE.



WARNING

HOT SURFACE



CAUTION

- AVOID BURNS!
- DO NOT TOUCH WHEN BARBECUE IS IN USE!
- EXTREMELY HOT SURFACE!

* SHADED AREAS BECOME EXTREMELY HOT WHEN IN USE.

WARRANTY AND SERVICE

BEFORE YOU CALL FOR SERVICE have the following information available:

1. **Serial number:** The serial number is located either on the cart side panel, the upper rear panel of your barbecue, or on the rating plate. You can also find the serial number on the front cover of the user manual.
2. **Model number:** The model number is located on the front cover of the user manual, the bottom right corner of the rating label and also on your cash register receipt.
3. **Proof of purchase** by the original owner.

Call the MASTER Chef® Customer Care Hotline 1-855-453-2150

HOURS: 9AM–7PM EST Mon-Fri, Closed Saturday and Sunday

IF YOUR PRODUCT IS DAMAGED:

1. Call the **MASTER Chef® Customer Care** Hotline **1-855-453-2150**.
2. Do not return to the store for replacement of damaged or defective parts. **MASTER Chef® Customer Care** will ensure that all in-stock replacement parts arrive at your home within 3–10 business days.
3. Concealed Loss or Damage: If damage is unnoticed until merchandise is unpacked, resolve issue by contacting **MASTER Chef® Customer Care** immediately. Missing or damaged parts should be claimed within 30 days of purchase.

**To ensure your satisfaction and for follow-up service,
register your barbecue online at www.masterchefbbqs.com**

LIMITED WARRANTY:

Trileaf Distributions® hereby warrants to the ORIGINAL PURCHASER of this MASTER Chef® Barbecue that it will be free of defects in workmanship, for one (1) year from the date of purchase, as follows:

Please see Limitations and Exclusions section on page 24.

LIMITED 1 YEAR: ALL PARTS

BATTERY DISPOSAL

Always dispose of used batteries according to local regulations.

CAUTION

Some parts may contain sharp edges—especially as noted in the manual! Wear protective gloves if necessary. For residential use ONLY. Do not use for commercial cooking.

WARNING

Do not attempt to repair or alter the hose/valve/regulator for any assumed defect or for any type of retrofit or conversion. Any modifications to this assembly will void your warranty and create the risk of a gas leak and fire. Use only authorized replacement parts supplied by the manufacturer for your model.

WARRANTY AND SERVICE

LIMITATION AND EXCLUSIONS

Trileaf Distribution® has the following **limitations** to its warranty:

1. This limited warranty is non-transferable and becomes void if barbecue is used for commercial or rental purposes.
2. This warranty applies only when barbecue is used in Canada.
3. Warranty is in lieu of all warranties, expressed or implied, and all other obligations or liabilities related to the sale or use of its grill products.
4. Trileaf Distribution® shall not be liable for incidental, consequential, special or contingent damages resulting from its breach of this written warranty or any implied warranty.
5. Trileaf Distribution® will repair or replace parts, at its option, proven defective under normal use and service and which on examination during the applicable warranty period (See exclusions to warranty coverage below).
6. Shipping and handling charges are the responsibility of the original consumer-purchaser for all in/out of warranty part orders.
7. This limited warranty will not reimburse you for the cost of any inconvenience, food, personal injury or property damage.
8. Trileaf Distribution® does not authorize any person or company to assume for it any other obligation or liability in connection with the sale, installation, use, removal, return, or replacement of its equipment; and no such representations are binding on Trileaf Distribution®.
9. Visit www.masterchefbbqs.com to register your product online. The purchaser shall retain a copy of the purchase invoice for future claims.

Trileaf Distribution® excludes from its warranty the following:

- a. Accidental damage, abuse, tampering or misuse, misapplication, vandalism, careless handling.
- b. Damages caused by improper assembly or installation, alteration, failure to follow proper usage, safety and maintenance instructions presented throughout this manual, including, improper clearance to combustible materials.
- c. Failure to perform regular maintenance, safety checks and service, including but not limited to removal of insects from venturi tubes, resulting in a flash fire, damage caused by grease fires, flare-up fires or fires resulting from improper connection of hose to gas source.
- d. Part failure due to lack of cleaning and maintenance, use of improper cleaning products, such as indoor stainless steel cleaners, abrasive and chemical cleaners, porcelain oven cleaner and other chemical cleaners which can cause damage to surfaces.
- e. Normal wear and tear, chipping and scratching on painted or porcelain enamel surfaces, dents, discolouration caused by environment or heat, surface corrosion, rust or rust perforation, chemical exposure in the atmosphere and other damages which result with normal use and are otherwise uncontrollable by the manufacturer.

There are no other express warranties except as set forth herein and any applicable implied warranties of merchantability and fitness are limited in duration to the period of coverage of this express written limited warranty.

To ensure your satisfaction
And for follow-up service, register your grill online at:
www.masterchefbbqs.com

**Trileaf Distribution Trifeuil
Toronto, Canada
M4S 2B8**

NOTES



NOTES



MASTER
Chef^{TM/MC}

www.masterchefbbqs.com

Customer support: 1-855-453-2150

