



S405 Barbecue Assembly Manual

85-3023-6 (G43705) Propane

1 YEAR LIMITED WARRANTY

**READ AND SAVE MANUAL FOR FUTURE REFERENCE.
If pre-assembled, leave this manual with unit for
consumer's future reference.**

**For product inquiries, parts, warranty and
troubleshooting support, please call 1-877-707-5463.**

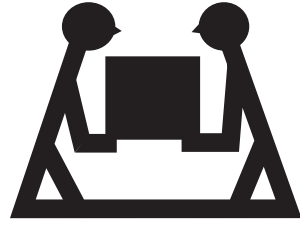

HEAVY ARTICLE NEEDS 2 TO LIFT

THIS MANUAL MUST REMAIN WITH THE PRODUCT AT ALL TIMES

To ORDER non-warranty replacement parts or accessories, or to register your warranty, please visit us on the web at www.masterchefbbqs.com

CAUTION

Sharp edges. Wear gloves when assembling your grill.

CAUTION

Read and follow all safety statements, assembly instructions, and use and care directions before attempting to assemble and cook.

INSTALLER OR ASSEMBLER/CONSUMER

This manual should be kept with the BBQ at all times.

WARNING

Failure to follow all of the Manufacturer's instructions could result in hazardous fires, explosions, property damage, or serious personal injury or even death.

Follow all leak check procedures carefully prior to operation of barbecue, even if grill was dealer assembled. Do not try to light this barbecue without reading the Lighting Instructions section of this manual.

DANGER

1. If you smell Gas:
 - a. Shut off gas to the appliance
 - b. Extinguish any open flame
 - c. Open lid
 - d. If odor continues, keep away from the appliance and immediately call your gas supplier or your fire department
2. Requires two people to complete the assembly process.
3. Beware of sharp edges.

WARNING

1. Do not store or use gasoline or other flammable liquids or vapours in the vicinity of this or any other appliance.
2. An LP cylinder not connected for use shall not be stored in the vicinity of this or any other appliance.

THIS BARBECUE IS FOR OUTDOOR USE ONLY

CONTACT CALL CENTRE IF ANY PARTS ARE MISSING

1-877-707-5463

HARDWARE PACK

TOOLS NEEDED FOR ASSEMBLY

- #2 Phillips screwdriver (long and short)
- ¼" Slotted screwdriver (long and short)
- Adjustable wrench
- Pliers

Before assembling the barbecue, read these instructions carefully.

Assemble the barbecue on a flat, clean surface. Grill is heavy. You should have at least two people assemble the barbecue together.

Notes: Do not fully tighten all the nuts during this initial stage.

KEY #	DESCRIPTION	PART NUMBER	QUANTITY
1	No. 10-24 x 13 Screw	20124-10013-036	36
2	No. 10-24 x 30 Screw	20124-10030-036	6
3	No. 10 Nut	31224-10000-036	45
4	Hinge Pin	G306-0005-9088	3
5	Wheel Spacer	G305-0024-9088	1
6	No. 10-24 wing nut	33300-10000-036	2
7	Fiber Washer B	G437-0050-9000	26
8	Fiber Washer (lid handle)	G306-0027-9300	2
9	Bolt (lid)	G306-0004-01	2
10	No. 8-32 x 10 Screw	20132-08010-036	2
11	No. 8 Wing Nut	33300-08000-032	1
12	Venturi clip, side burner	G305-0057-9000	1
13	No. 10-24 x 16 Screw	20124-10016-036	8
14	ST4.2 x 8 Tapping screw	24200-42008-136	10
15	No. 8-32 x 18 Screw	20132-08018-036	4
16	1/4"-20 x 65 Carriage bolt	11920-13065-036	1
17	1/4"-20 Wing nut	33300-13000-036	1
18	No. 8-32 Nut	31232-08000-036	4

Caution: Sheet metal can cause injury. Wear gloves when installing the grill.

1		2		3	
4		5		6	
7		8		9	
10		11		12	
13		14		15	
16		17		18	

PARTS LIST (PROPANE) FOR 85-3023-6 (G43705)

KEY #	QUANTITY	DESCRIPTION	PART NO.
AA	1	Top lid assembly	G437-0054-01
AB	1	Thermometer	G305-0039-01
AC	1	Logo	G451-0001-01
AD	2	Upper hinge	G206-0002-A2
AE	1	Top lid handle	G306-0002-01
AF	2	Rubber pad	G303-0038-01
BA	1	Burner box assembly	G437-5400-01
BB	2	Lower hinge	G210-0019-01
BC	1	Burner	G437-5500-01
BD	1	Heat shield	G437-0023-01
BE	1	Electrode set, main burners	G437-0055-01
BF	1	Flame tamers	G434-0005-01
BG	2	Cooking grates	G437-6300-01
BH	1	Warming rack	G437-0051-01
CA	1	Control panel	G437-0056-01
CB	1	Valve assembly	G437-5800-01
CC	1	Side burner metal hose	G434-0059-01
CD	1	Side burner valve	G437-0053-01
CE	1	Regulator	G614-0035-01
CF	4	Control knob	G306-0012-01
CG1	1	Electronic Ignitor	G430-0008-01
CG2	1	Electronic Ignitor button	G501-0072-A1
CH	1	Grease cup hook	G305-0043-01
CI	1	Grease cup	G430-0033-02
DA	1	Cart side panel, right	G437-0800-01
DB	1	Cart side panel, left	G437-0700-01
DC	1	Upper, back brace	G437-0011-01
DD	1	Lower, back brace	G437-0012-01
DE	1	Upper, front panel	G437-0057-01
DF	1	Tank Exclusion	G437-0017-01
DG	1	Lower, front panel	G437-0058-01
DH	1	Front, end caps	G437-0028-01
DI	1	Back, end caps	G437-0029-01
DJ	1	Match holder	G401-0079-01
DK	1	Heat shield	G210-0012-01
DL	1	Tank retainer clip	G206-0028-02
DM	2	Wheel	G210-0018-02
DN	1	Wheel axle	G437-0007-01
DO	1	Support bar	G437-0061-01
DP	1	Right support bracket	G437-0062-01
EA	1	Side shelf table- right	G437-6100-01
EB	1	Side shelf fascia - right	G437-0059-01
EC	1	Side burner table - left	G437-6200-01
ED	1	Side shelf fascia - left	G437-0060-01
EE	1	Side burner	G434-5500-01
EF	1	Electrode wire, side burner	G431-0034-01
EG	1	Side burner drip pan	G304-0016-02
EH	1	Side burner grate	G303-0022-01
F1	1	Hardware pack	G437-B005-01
F2	1	Assembly instructions	G437-M005-01
F3	1	Safe Use and Care Manual	G207-M015-02

EXPLODED DIAGRAM (PROPANE) FOR 85-3023-6 (G43705)

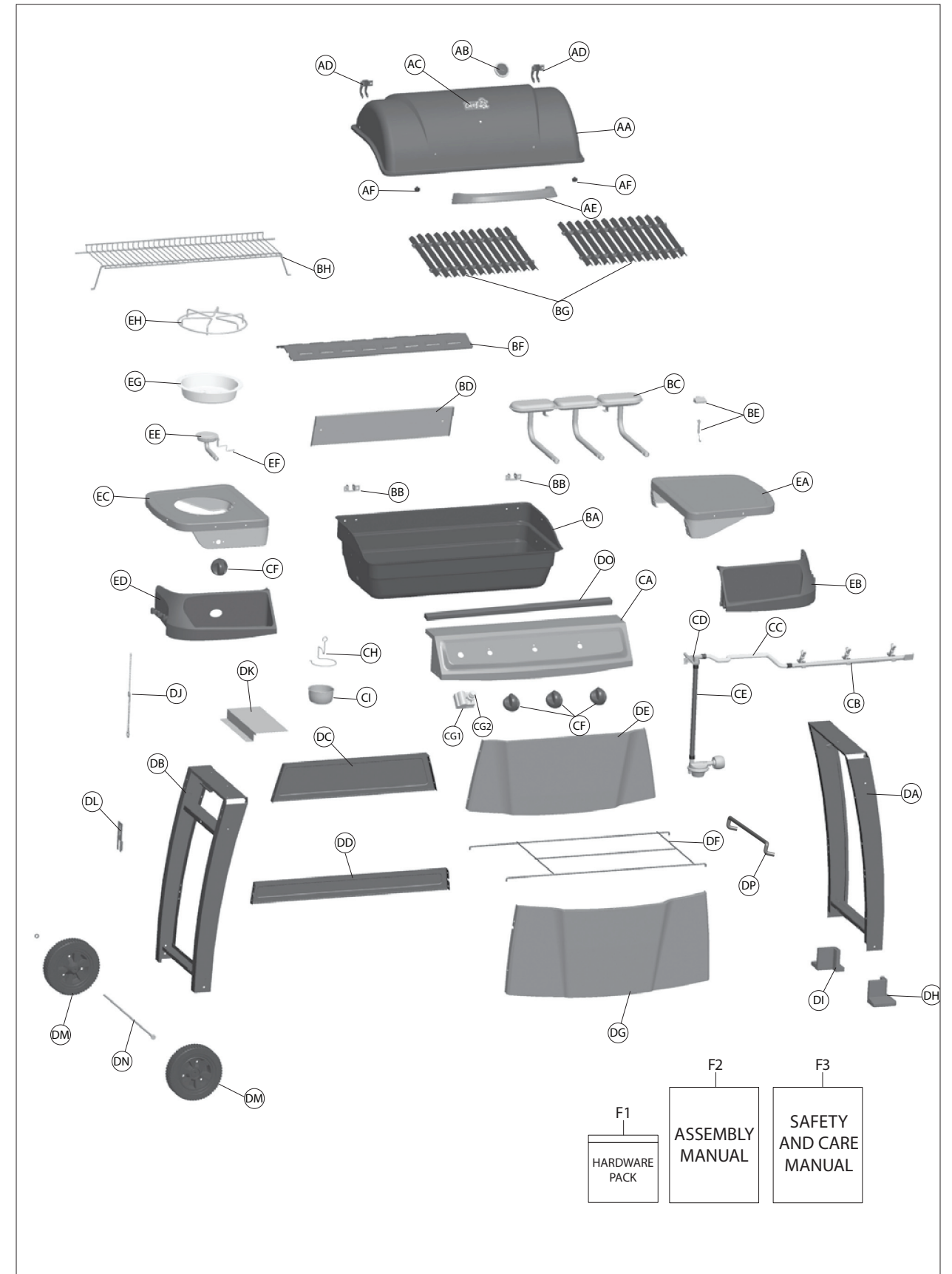

ASSEMBLY INSTRUCTIONS

1

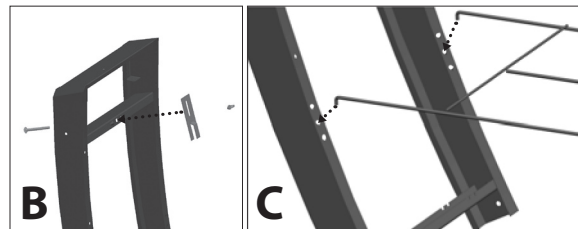
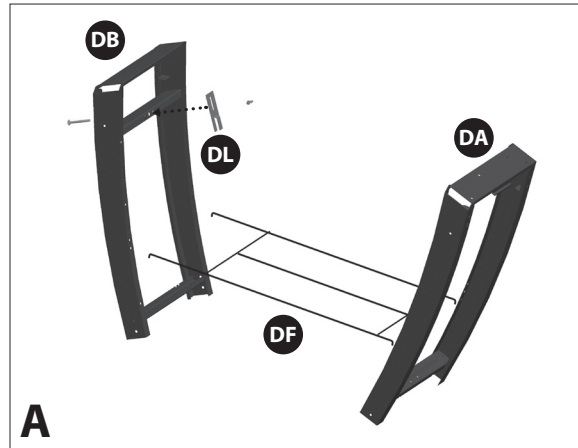

TWO PEOPLE REQUIRED FOR ALL ASSEMBLY STEPS

Assemble the tank retainer clip (DL) to the left cart side panel (DB), as shown in Figure B.

Insert the tank exclusion (DF) into the right and left cart side panels (DA & DB), as shown. Make sure to insert the tank exclusion (DF) into the holes of the cart panels, as shown in Figure C.

YOU WILL NEED:

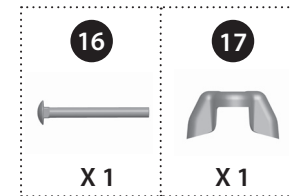

2

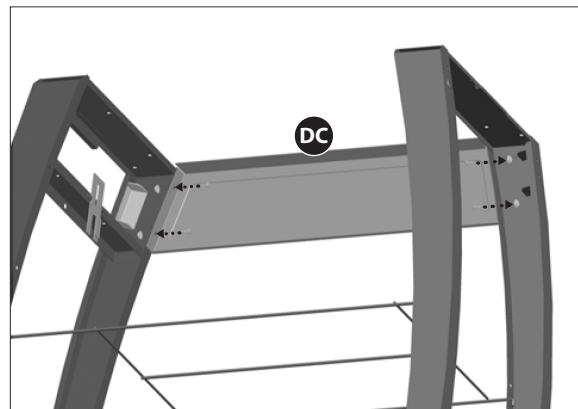

Front View

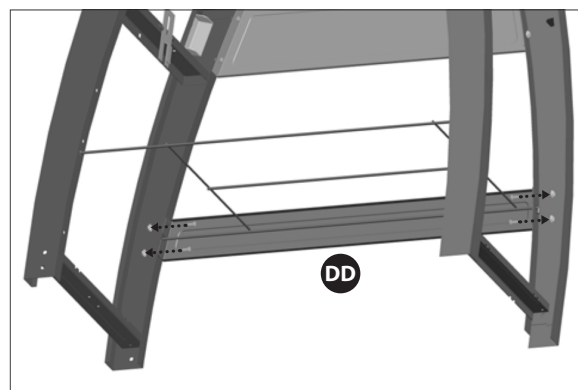

Front View

Assemble the upper and lower back braces (DC & DD) to both cart side panels, as shown.

YOU WILL NEED:

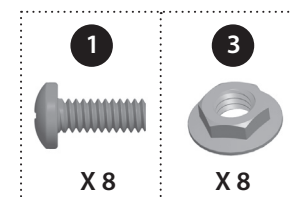

ASSEMBLY INSTRUCTIONS

3

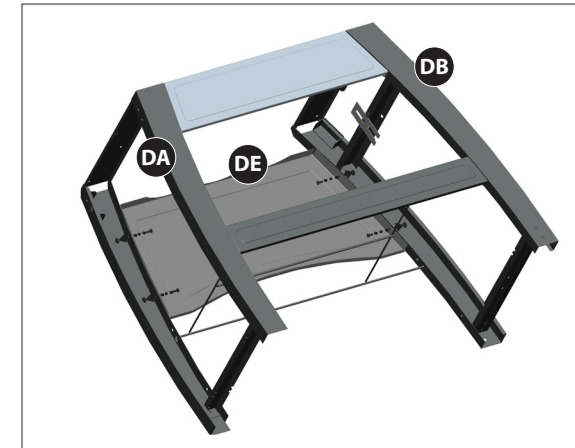

a. Assemble the upper front panel (DE) to the left and right, front cart side panels (DB & DA), as shown.

YOU WILL NEED:

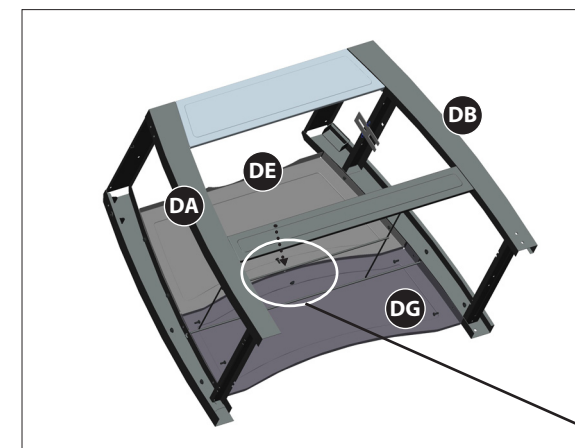
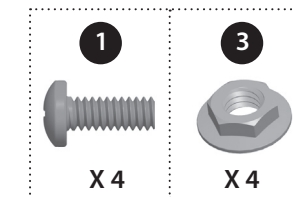

Back View

b. Assemble the lower front panel (DG) to the upper front panel (DE) and Cart side panels (DA and DB), as shown.

YOU WILL NEED:

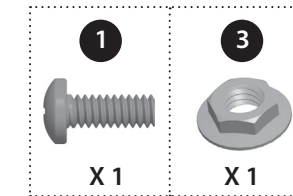

YOU WILL NEED:

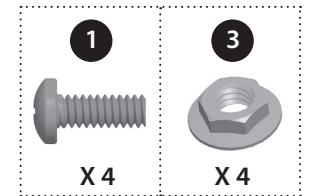

lower front panel to upper front panel

Lower front panel to cart side panel

c. Assemble the support bar (DO) to both cart side panels (DA & DB), as shown.

YOU WILL NEED:

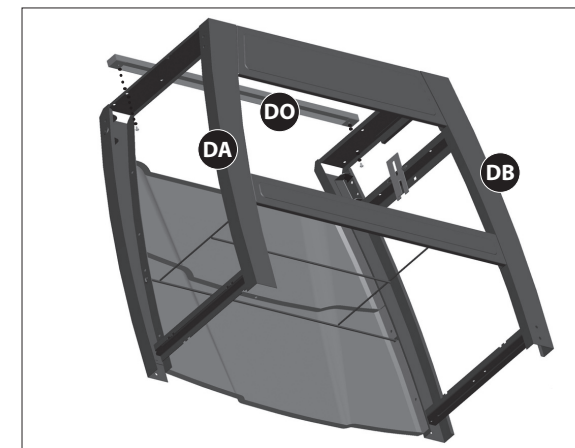
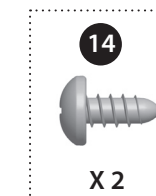

d. Assemble the right support bracket (DP) to the cart side panel, right (DA). To assemble, insert the right support bracket (DP) into the holes on the cart side panel, right (DA), as shown

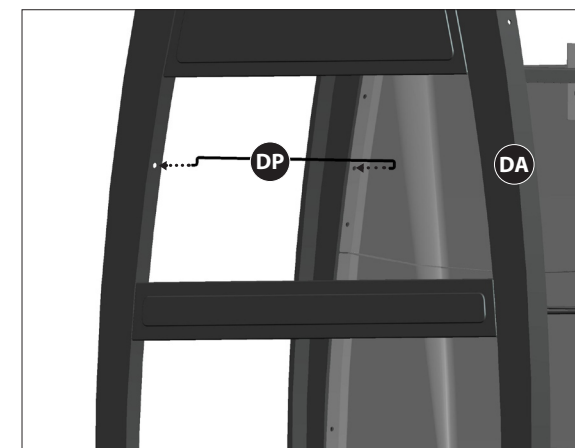

ASSEMBLY INSTRUCTIONS

4

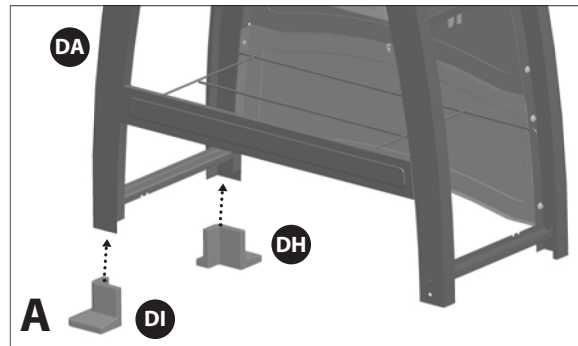

a. Insert the front and back end caps (DH & DI) to the bottom of the right cart panel (DA), as shown.

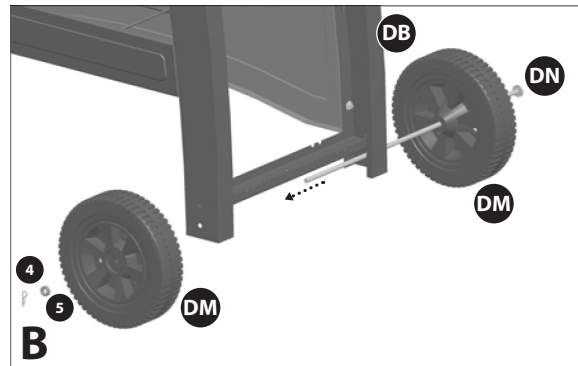

b. Insert the wheel axle (DN) through the first wheel (DM) and the bottom of the left cart panel (DB). "Cone" side of the wheel should be against left cart leg, as shown in Figure C.

c. Slide the second wheel (DM) onto the wheel axle (DN) and attach hardware #5 and #4.

YOU WILL NEED:

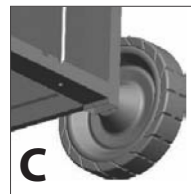
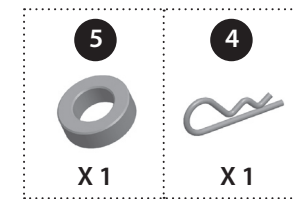

5



a. Assemble the tank heat shield (DK) to the center support bar located on the left cart side panel (DB), as shown.

YOU WILL NEED:

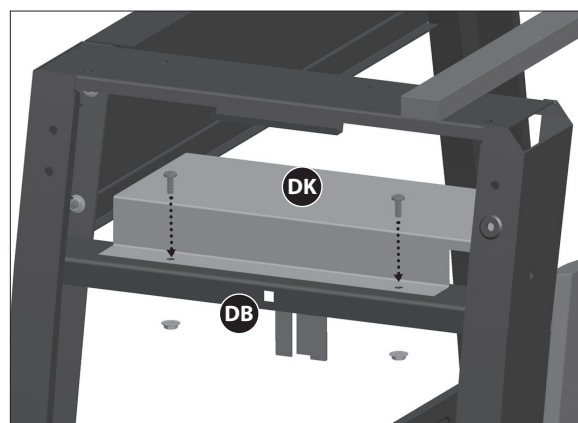
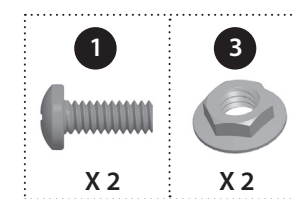

ASSEMBLY INSTRUCTIONS

6

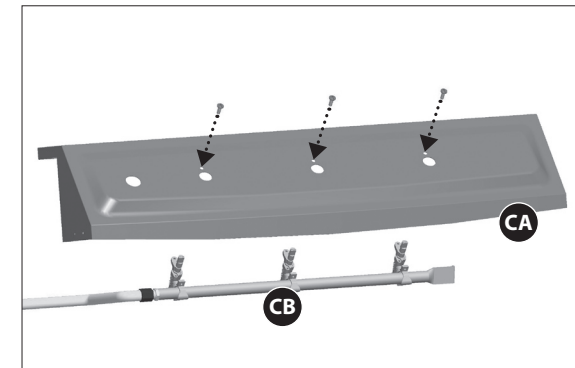

a. Assemble the valve assembly (CB) to the control panel (CA).

YOU WILL NEED:

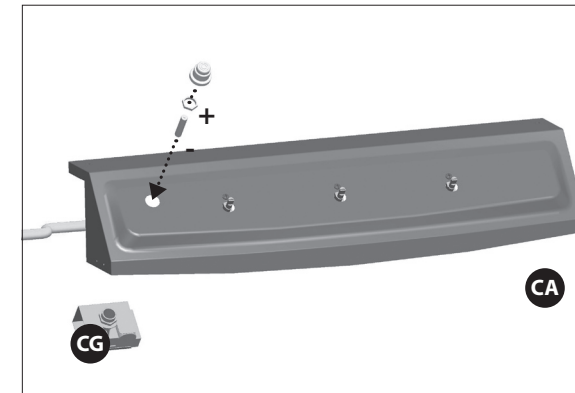
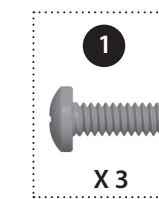

b. Remove the Electronic ignition button (CG2) from the electronic ignition (CG1). Assemble the electronic ignition (CG1) through the back of the control panel (CA), as shown.

c. Insert one "AA" battery into the electronic ignition (CG1) battery compartment, with the positive side facing upwards. (Battery not included) Attach the electronic ignition button (CG2) to complete assembly.

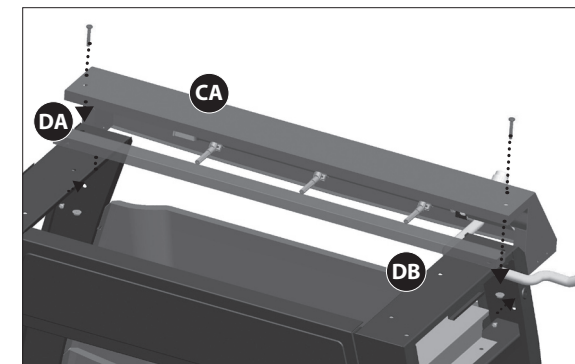

d. Assemble the control panel (CA) to the top of the left and right cart side panels (DA & DB), as shown.

YOU WILL NEED:

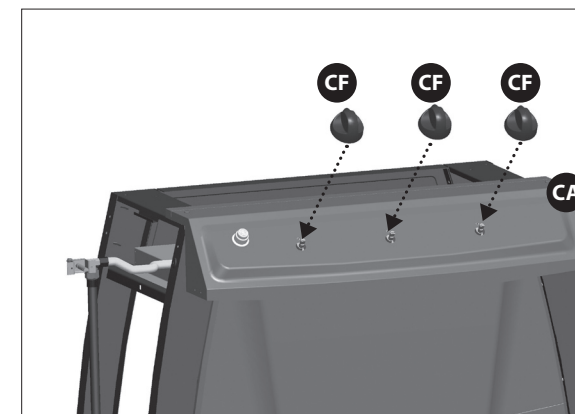
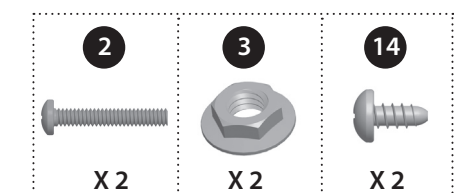

e. Place the control knobs (CF) onto the stems of the valve assembly (CB), located on the control panel (CA).

ASSEMBLY INSTRUCTIONS

7

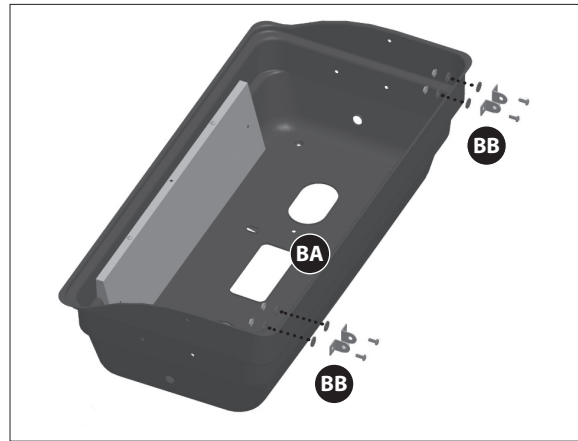

a. Assemble the lower hinge (BB x2) on the back of the burner box assembly (BA) as shown.

YOU WILL NEED:

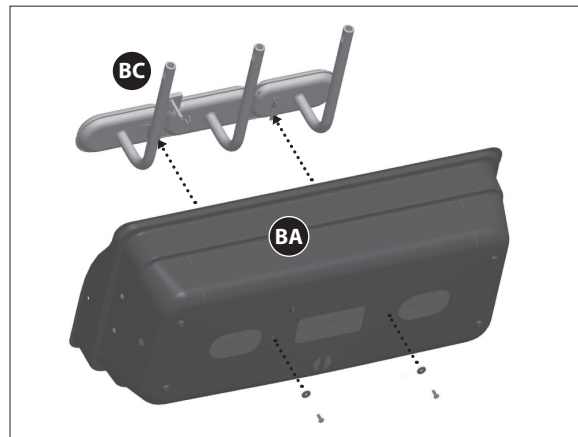
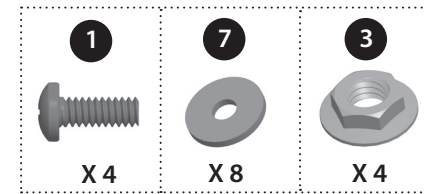

b. Assemble the burner (BC) to the burner box (BA) by positioning the burner venturi tubes (BC) through the openings in the bottom of the burner box (BA), as shown. Ensure that the burner venturi tubes are facing forward.

YOU WILL NEED:

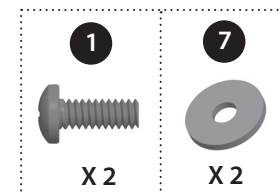

8

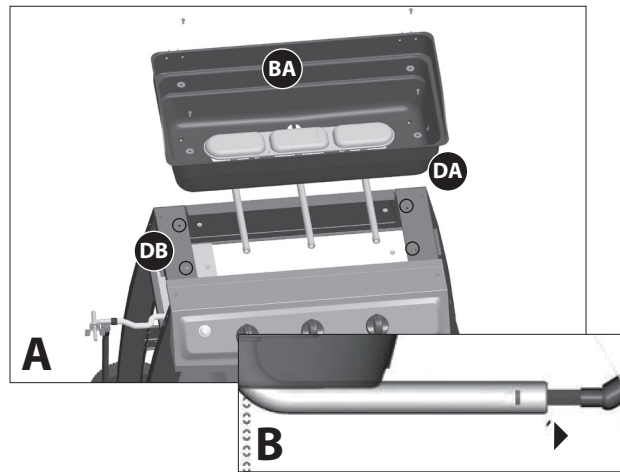

a. Position the Burner box assembly (BA) onto the burner box support brace (DA & DB) located at the top of the right and left cart side panels.

b. **TIP: Before assembling, make sure that the burner venturi tubes (BC) engage the valve assembly (CB), as shown in figure B.**

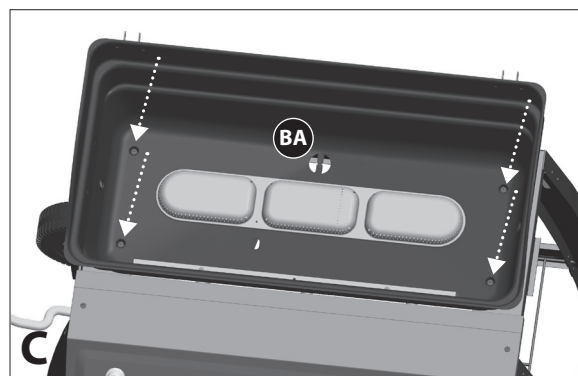

c. Assemble the burner box assembly (BA) to the burner box supports (DA & DB).

YOU WILL NEED:

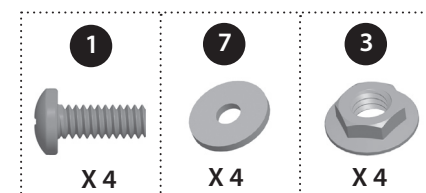

IMPORTANT: Ensure that the fiber washers are secured inside the burner box assembly to properly seal the lower casting.

ASSEMBLY INSTRUCTIONS

9

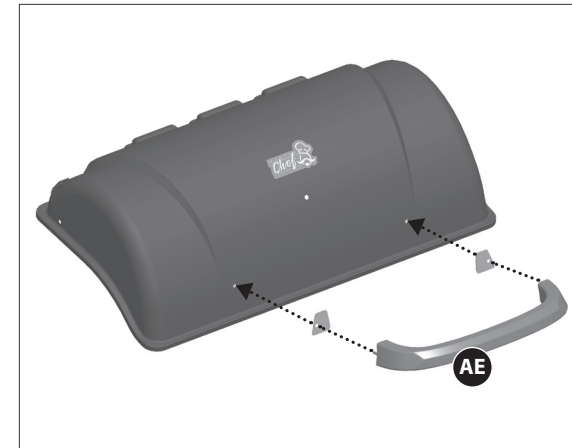

a. Assemble the top lid handle (AE) to the top lid (AA).

YOU WILL NEED:

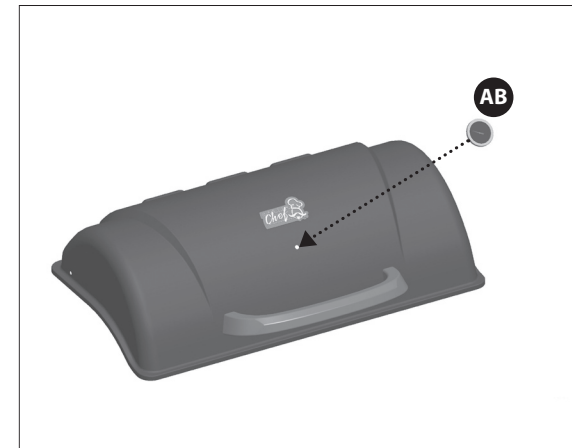
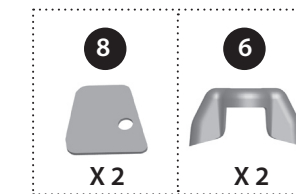

b. Assemble the thermometer (AB) to the top lid (AA).

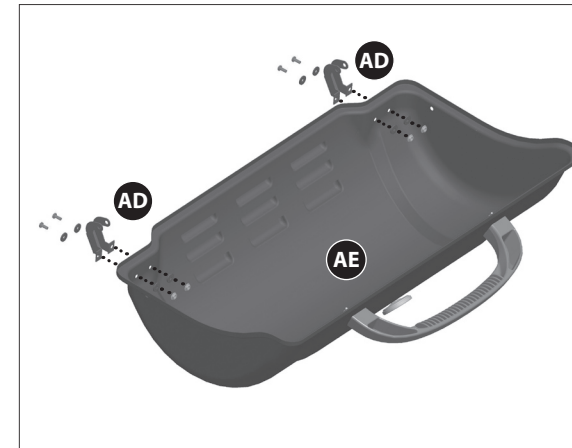

c. Assemble the upper hinge (AD x2) to the top lid assembly (AA).

YOU WILL NEED:

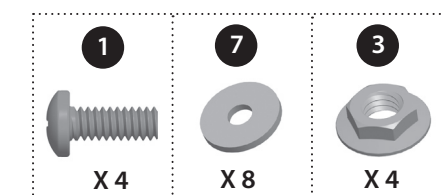

ASSEMBLY INSTRUCTIONS

10

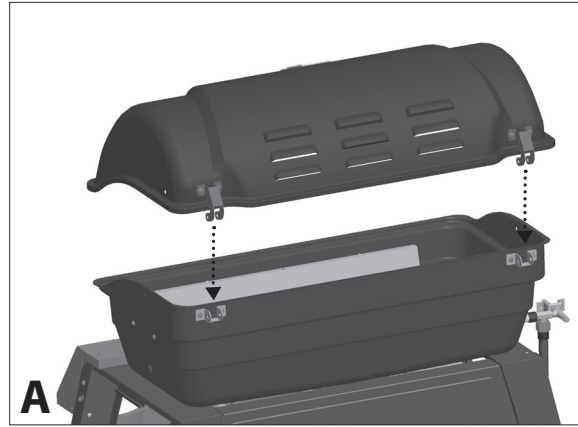

Assemble the lid (AA) to the Burner box (BA), as shown in figure A&B.

YOU WILL NEED:

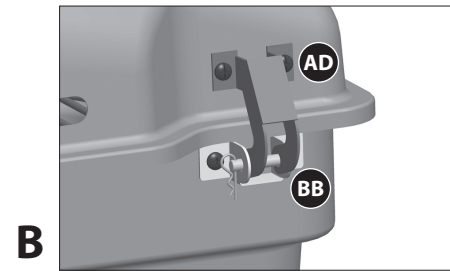
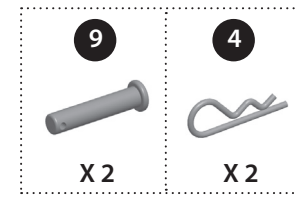

ASSEMBLY INSTRUCTIONS

12

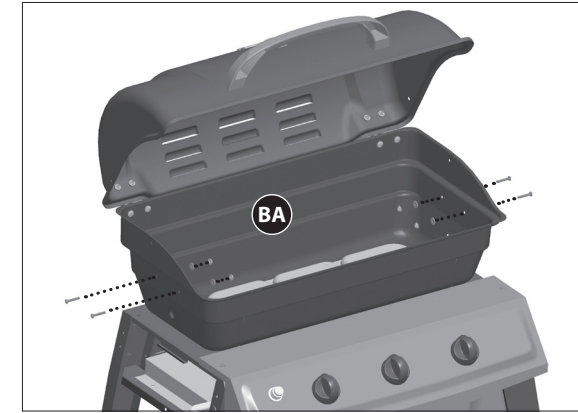

Install the hardware into the burner box assembly (BA) to support the flame tamer (BF).

YOU WILL NEED:

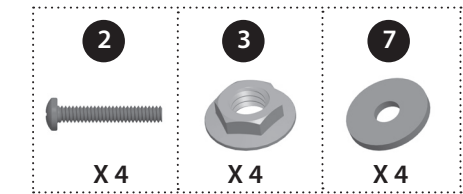

11

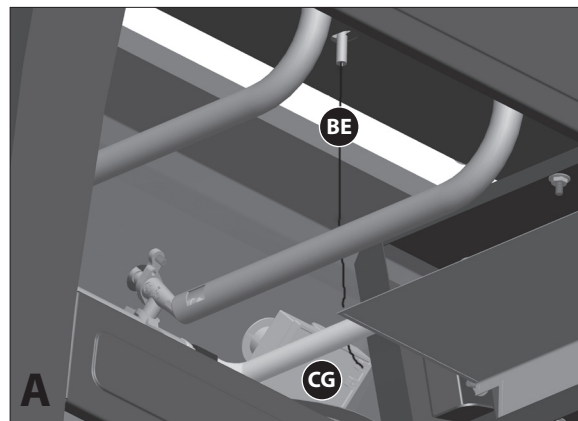

Connect the main burner electrode wire (BE), already pre-assembled to the main burner (BC), to the electronic ignition (CG1), located on the back of the control panel, as shown in figure B.

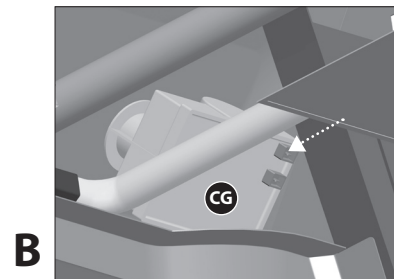

13

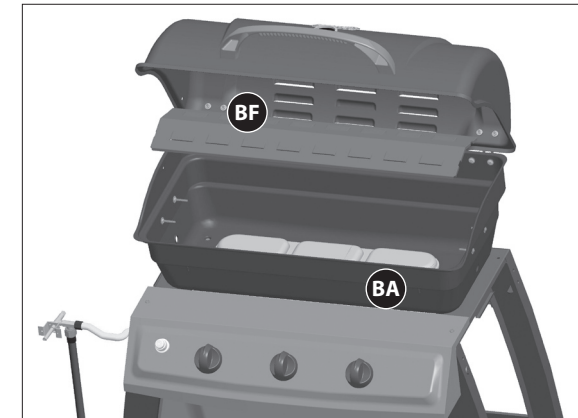

Position the flame tamer (BF) onto the hardware assembled in step 12.

ASSEMBLY INSTRUCTIONS

14

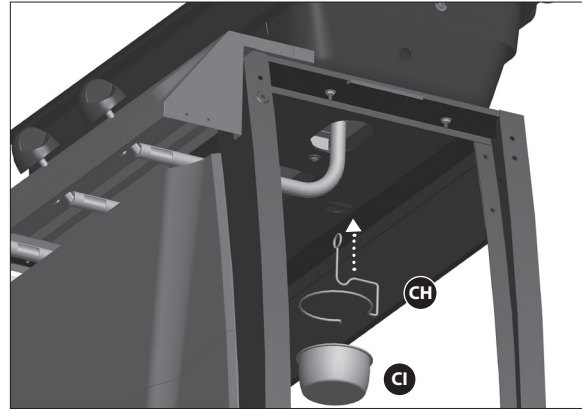

Attach the grease cup hook (CH) to the bottom of the burner box assembly (BA) as shown. Position the grease cup (CI) into the grease cup hook (CH), as shown.

CAUTION: Failure to assemble grease cup (CI) and grease cup hook (CH) will cause hot grease to drip from the bottom of the burner box, with the risk of fire, property damage, or personal injury.

15

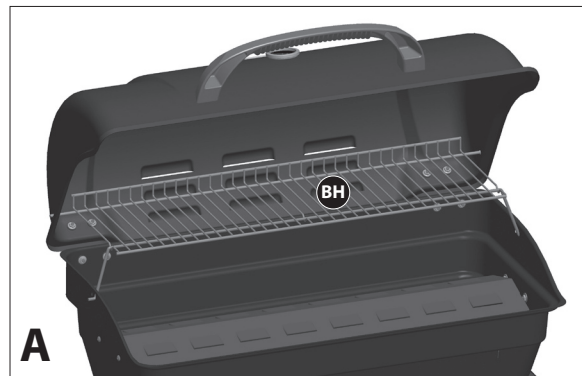

a. To assemble the warming rack (BH), insert the stationary wire into the holes on the sides of the lid assembly (AA). Insert warming rack pivot legs (BH) into the holes on the inside of the burner box assembly (BA).

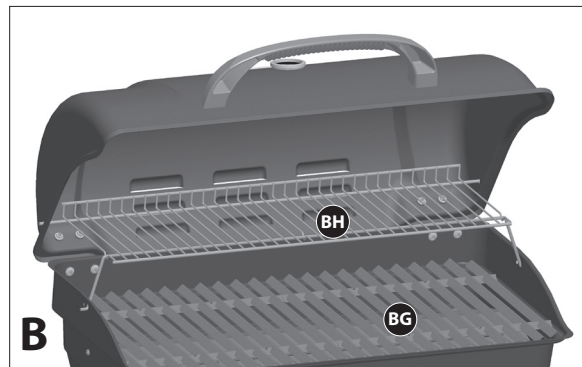
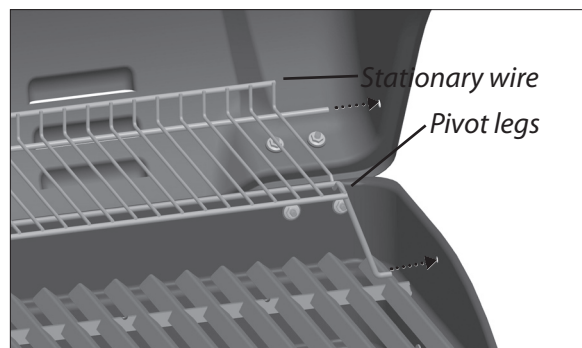

b. Place the cooking grate (BG) into the burner box assembly (BA), as shown.

ASSEMBLY INSTRUCTIONS

16



Assemble right side shelf table (EA), and left side burner table (EC) to the left and right cart side panels, as shown.

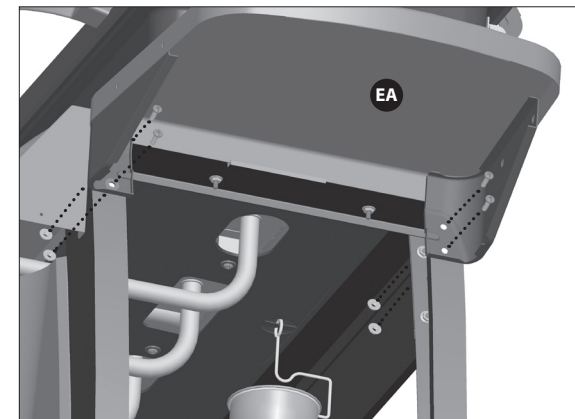

YOU WILL NEED:

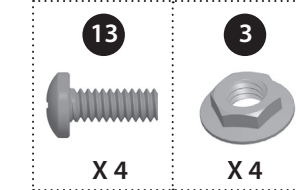

Right side shelf table

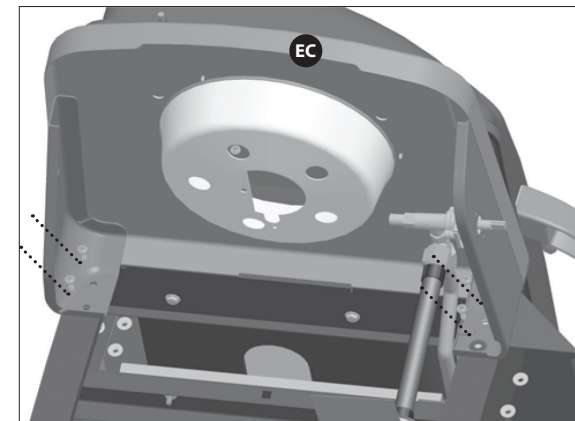

YOU WILL NEED:

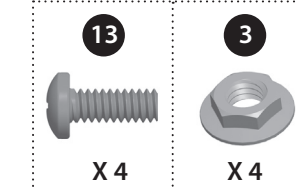

Left side burner table

ASSEMBLY INSTRUCTIONS

17

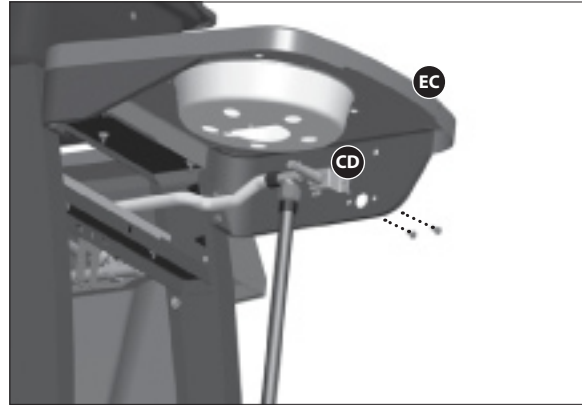

a. Assemble the side burner valve (CD) onto the control panel of the side burner table (EC), as shown.

YOU WILL NEED:

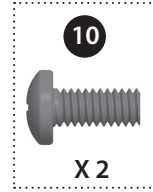

b. Place the side burner (EE) into the side burner drip pan (EG) and secure using hardware.

YOU WILL NEED:

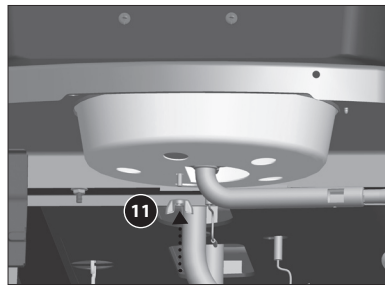
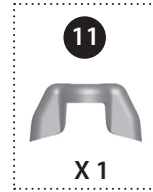

ASSEMBLY INSTRUCTIONS

18

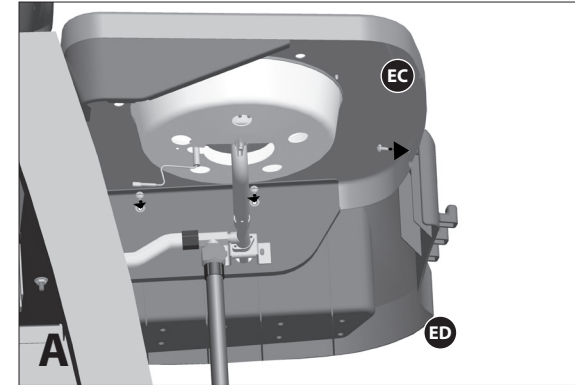

a. Attach the side burner shelf fascia (ED) to the side burner shelf table (EC) and the control panel (CA), as shown.

YOU WILL NEED:

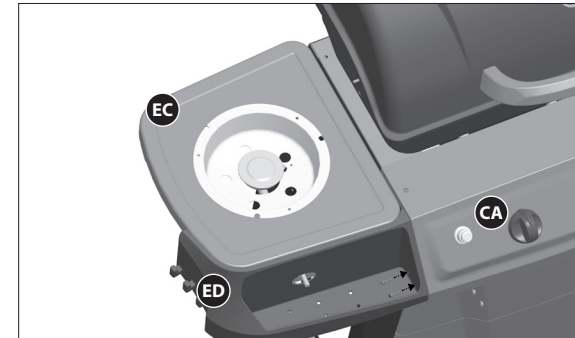
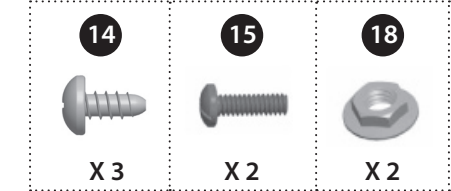

b. Attach the right side shelf fascia (EB) to the right side shelf table (EA) and the control panel (CA), as shown.

YOU WILL NEED:

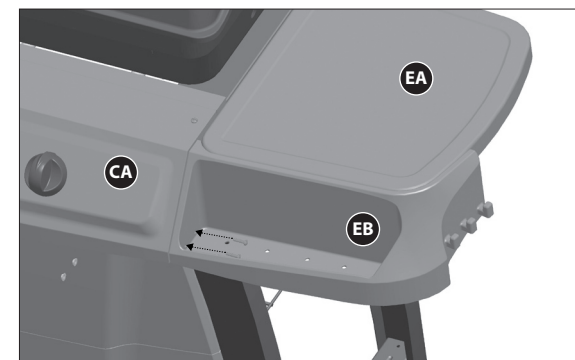
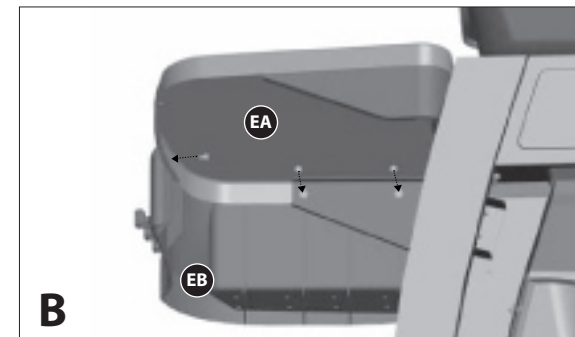
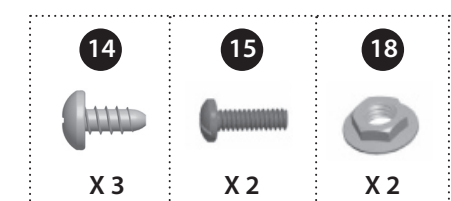

c. Place side burner grate (EH) onto side burner table (EB). Attach the control knob (CF) to the side burner valve (CD), as shown.



ASSEMBLY INSTRUCTIONS

19

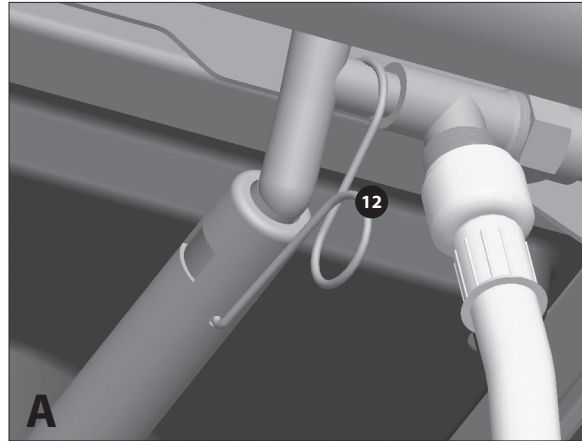

- a. Use the side burner clip (#12) to secure the side burner orifice to the side burner valve (CD).

YOU WILL NEED:

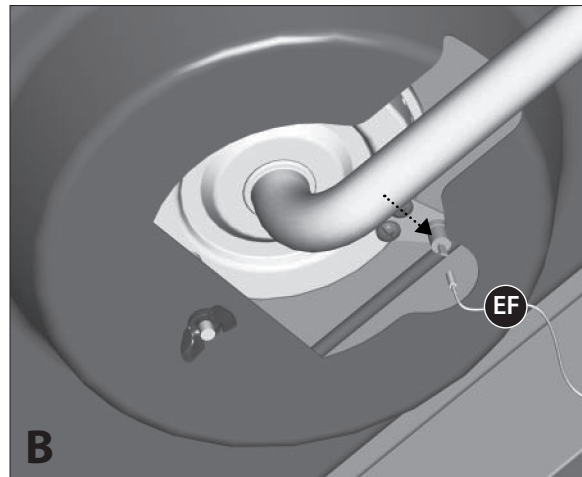
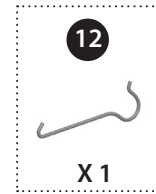

- b. Connect the side burner electrode wire (EF) pre-assembled to the side burner (EE) (figure B), to the electronic ignition (CG1), located on the back of the control panel, as shown in figure C.

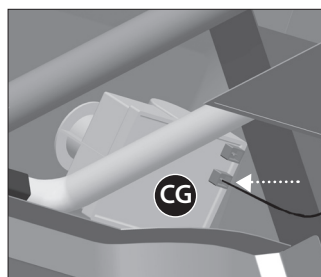
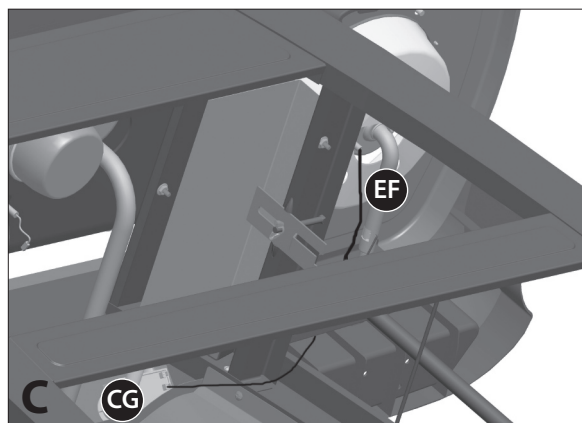

ASSEMBLY INSTRUCTIONS

20

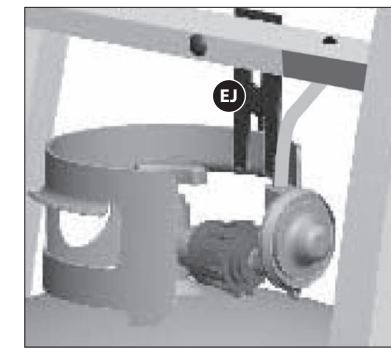

LP CYLINDER IS SOLD SEPARATELY.

Fill and leak test the LP cylinder before attaching to BBQ. Once LP cylinder has been filled and leak checked, locate the tank support bar on the bottom of the left cart side panel and place LP cylinder in the grooves of the tank support bar. Slide tank retainer clip (DL) over cylinder collar and tighten knob. Connect the regulator (CE) to the gas tank OPD valve.